

Introduction - Physics

The following released test questions are taken from the Physics Standards Test. This test is one of the California Standards Tests administered as part of the Standardized Testing and Reporting (STAR) Program under policies set by the State Board of Education.

All questions on the California Standards Tests are evaluated by committees of content experts, including teachers and administrators, to ensure their appropriateness for measuring the California academic content standards in Physics. In addition to content, all items are reviewed and approved to ensure their adherence to the principles of fairness and to ensure no bias exists with respect to characteristics such as gender, ethnicity, and language.

This document contains released test questions from the California Standards Test forms in 2003, 2004, 2005, 2006, 2007, and 2008. First on the pages that follow are lists of the standards assessed on the Physics Test. Next are released test questions. Following the questions is a table that gives the correct answer for each question, the content standard that each question is measuring, and the year each question last appeared on the test. Reference sheets, provided for students taking the test, are also included as they are necessary in answering some of the questions. It should be noted that asterisked (*) standards found in the *Science Content Standards for California Public Schools, Kindergarten through Grade 12*, are not assessed on the California Standards Tests in Science and, therefore, are not represented in these released test questions.

The following table lists each reporting cluster, the number of items that appear on the exam, and the number of released test questions that appear in this document. The released test questions for Biology, Chemistry, Earth Science, and Physics are the same test questions found in different combinations on the Integrated Science 1, 2, 3, and 4 tests.

REPORTING CLUSTER	NUMBER OF QUESTIONS ON EXAM	NUMBER OF RELEASED TEST QUESTIONS
Investigation and Experimentation (Standards: PH1E1. a-n)	6	8
Motion and Forces (Standards: PH1. a-g)	12	17
Conservation of Energy and Momentum (Standards: PH2. a-g)	12	19
Heat and Thermodynamics (Standards: PH3. a-e)	9	14
Waves (Standards: PH4. a-f)	10	15
Electric and Magnetic Phenomena (Standards: PH5. a-i)	11	16
TOTAL	60	89

In selecting test questions for release, three criteria are used: (1) the questions adequately cover a selection of the academic content standards assessed on the Physics Test; (2) the questions demonstrate a range of difficulty; and (3) the questions present a variety of ways standards can be assessed. These released test questions do not reflect all of the ways the standards may be assessed. Released test questions will not appear on future tests.

For more information about the California Standards Tests, visit the California Department of Education's Web site at <http://www.cde.ca.gov/ta/tg/sr/resources.asp>.

THE INVESTIGATION AND EXPERIMENTATION REPORTING CLUSTER

The following 14 California content standards are included in the Investigation and Experimentation reporting cluster and are represented in this booklet by eight test questions. These questions represent only some ways in which these standards may be assessed on the California Physics Standards Test.

CALIFORNIA CONTENT STANDARDS IN THIS REPORTING CLUSTER

Investigation and Experimentation

-
- PHIE1.** Scientific progress is made by asking meaningful questions and conducting careful investigations. As a basis for understanding this concept and addressing the content in the other five reporting clusters, students should develop their own questions and perform investigations. Students will:
-
- PHIE1. a.** Select and use appropriate tools and technology (such as computer-linked probes, spreadsheets, and graphing calculators) to perform tests, collect data, analyze relationships, and display data.
-
- PHIE1. b.** Identify and communicate sources of unavoidable experimental error.
-
- PHIE1. c.** Identify possible reasons for inconsistent results, such as sources of error or uncontrolled conditions.
-
- PHIE1. d.** Formulate explanations by using logic and evidence.
-
- PHIE1. e.** Solve scientific problems by using quadratic equations and simple trigonometric, exponential, and logarithmic functions.
-
- PHIE1. f.** Distinguish between hypothesis and theory as scientific terms.
-
- PHIE1. g.** Recognize the usefulness and limitations of models and theories as scientific representations of reality.
-
- PHIE1. h.** Read and interpret topographic and geologic maps.
-
- PHIE1. i.** Analyze the locations, sequences, or time intervals that are characteristic of natural phenomena (e.g., relative ages of rocks, locations of planets over time, and succession of species in an ecosystem).
-
- PHIE1. j.** Recognize the issues of statistical variability and the need for controlled tests.
-
- PHIE1. k.** Recognize the cumulative nature of scientific evidence.
-
- PHIE1. l.** Analyze situations and solve problems that require combining and applying concepts from more than one area of science.
-
- PHIE1. m.** Investigate a science-based societal issue by researching the literature, analyzing data, and communicating the findings. Examples of issues include irradiation of food, cloning of animals by somatic cell nuclear transfer, choice of energy sources, and land and water use decisions in California.
-
- PHIE1. n.** Know that when an observation does not agree with an accepted scientific theory, the observation is sometimes mistaken or fraudulent (e.g., the Piltdown Man fossil or unidentified flying objects) and that the theory is sometimes wrong (e.g., the Ptolemaic model of the movement of the Sun, Moon, and planets).
-

THE MOTION AND FORCES REPORTING CLUSTER

The following seven California content standards are included in the Motion and Forces reporting cluster and are represented in this booklet by 17 test questions. These questions represent only some ways in which these standards may be assessed on the California Physics Standards Test.

CALIFORNIA CONTENT STANDARDS IN THIS REPORTING CLUSTER

Motion and Forces

PH1.	Newton's laws predict the motion of most objects. As a basis for understanding this concept:
PH1. a.	<i>Students know</i> how to solve problems that involve constant speed and average speed.
PH1. b.	<i>Students know</i> that when forces are balanced, no acceleration occurs; thus an object continues to move at a constant speed or stays at rest (Newton's first law).
PH1. c.	<i>Students know</i> how to apply the law $F = ma$ to solve one-dimensional motion problems that involve constant forces (Newton's second law).
PH1. d.	<i>Students know</i> that when one object exerts a force on a second object, the second object always exerts a force of equal magnitude and in the opposite direction (Newton's third law).
PH1. e.	<i>Students know</i> the relationship between the universal law of gravitation and the effect of gravity on an object at the surface of Earth.
PH1. f.	<i>Students know</i> applying a force to an object perpendicular to the direction of its motion causes the object to change direction but not speed (e.g., Earth's gravitational force causes a satellite in a circular orbit to change direction but not speed).
PH1. g.	<i>Students know</i> circular motion requires the application of a constant force directed toward the center of the circle.

THE CONSERVATION OF ENERGY AND MOMENTUM REPORTING CLUSTER

The following seven California content standards are included in the Conservation of Energy and Momentum reporting cluster and are represented in this booklet by 19 test questions. These questions represent only some ways in which these standards may be assessed on the California Physics Standards Test.

CALIFORNIA CONTENT STANDARDS IN THIS REPORTING CLUSTER

Conservation of Energy and Momentum

- | | |
|----------------|---------------------------------------------------------------------------------------------------------------------------------------------------------------------------------------------|
| PH2. | The laws of conservation of energy and momentum provide a way to predict and describe the movement of objects. As a basis for understanding this concept: |
| PH2. a. | <i>Students know</i> how to calculate kinetic energy by using the formula $E = (1/2) mv^2$. |
| PH2. b. | <i>Students know</i> how to calculate changes in gravitational potential energy near Earth by using the formula (change in potential energy) = mgh (h is the change in the elevation). |
| PH2. c. | <i>Students know</i> how to solve problems involving conservation of energy in simple systems, such as falling objects. |
| PH2. d. | <i>Students know</i> how to calculate momentum as the product mv . |
| PH2. e. | <i>Students know</i> momentum is a separately conserved quantity different from energy. |
| PH2. f. | <i>Students know</i> an unbalanced force on an object produces a change in its momentum. |
| PH2. g. | <i>Students know</i> how to solve problems involving elastic and inelastic collisions in one dimension by using the principles of conservation of momentum and energy. |
-

THE HEAT AND THERMODYNAMICS REPORTING CLUSTER

The following five California content standards are included in the Heat and Thermodynamics reporting cluster and are represented in this booklet by 14 test questions. These questions represent only some ways in which these standards may be assessed on the California Physics Standards Test.

CALIFORNIA CONTENT STANDARDS IN THIS REPORTING CLUSTER

Heat and Thermodynamics

PH3.	Energy cannot be created or destroyed, although in many processes energy is transferred to the environment as heat. As a basis for understanding this concept:
PH3. a.	<i>Students know</i> heat flow and work are two forms of energy transfer between systems.
PH3. b.	<i>Students know</i> that the work done by a heat engine that is working in a cycle is the difference between the heat flow into the engine at high temperature and the heat flow out at a lower temperature (first law of thermodynamics) and that this is an example of the law of conservation of energy.
PH3. c.	<i>Students know</i> the internal energy of an object includes the energy of random motion of the object's atoms and molecules, often referred to as <i>thermal energy</i> . The greater the temperature of the object, the greater the energy of motion of the atoms and molecules that make up the object.
PH3. d.	<i>Students know</i> that most processes tend to decrease the order of a system over time and that energy levels are eventually distributed uniformly.
PH3. e.	<i>Students know</i> that entropy is a quantity that measures the order or disorder of a system and that this quantity is larger for a more disordered system.

THE WAVES REPORTING CLUSTER

The following six California content standards are included in the Waves reporting cluster and are represented in this booklet by 15 test questions. These questions represent only some ways in which these standards may be assessed on the California Physics Standards Test.

CALIFORNIA CONTENT STANDARDS IN THIS REPORTING CLUSTER

Waves

PH4.	Waves have characteristic properties that do not depend on the type of wave. As a basis for understanding this concept:
PH4. a.	<i>Students know waves carry energy from one place to another.</i>
PH4. b.	<i>Students know how to identify transverse and longitudinal waves in mechanical media, such as springs and ropes, and on the earth (seismic waves).</i>
PH4. c.	<i>Students know how to solve problems involving wavelength, frequency, and wave speed.</i>
PH4. d.	<i>Students know sound is a longitudinal wave whose speed depends on the properties of the medium in which it propagates.</i>
PH4. e.	<i>Students know radio waves, light, and X-rays are different wavelength bands in the spectrum of electromagnetic waves whose speed in a vacuum is approximately 3×10^8 m/s (186,000 miles/second).</i>
PH4. f.	<i>Students know how to identify the characteristic properties of waves: interference (beats), diffraction, refraction, Doppler effect, and polarization.</i>

THE ELECTRIC AND MAGNETIC PHENOMENA REPORTING CLUSTER

The following nine California content standards are included in the Electric and Magnetic Phenomena reporting cluster and are represented in this booklet by 16 test questions. These questions represent only some ways in which these standards may be assessed on the California Physics Standards Test.

CALIFORNIA CONTENT STANDARDS IN THIS REPORTING CLUSTER

Electric and Magnetic Phenomena

PH5.	Electric and magnetic phenomena are related and have many practical applications. As a basis for understanding this concept:
PH5. a.	<i>Students know</i> how to predict the voltage or current in simple direct current (DC) electric circuits constructed from batteries, wires, resistors, and capacitors.
PH5. b.	Students know how to solve problems involving Ohm's law.
PH5. c.	<i>Students know</i> any resistive element in a DC circuit dissipates energy, which heats the resistor. Students can calculate the power (rate of energy dissipation) in any resistive circuit element by using the formula $\text{Power} = IR$ (potential difference) $\times I$ (current) $= I^2R$.
PH5. d.	<i>Students know</i> the properties of transistors and the role of transistors in electric circuits.
PH5. e.	<i>Students know</i> charged particles are sources of electric fields and are subject to the forces of the electric fields from other charges.
PH5. f.	<i>Students know</i> magnetic materials and electric currents (moving electric charges) are sources of magnetic fields and are subject to forces arising from the magnetic fields of other sources.
PH5. g.	<i>Students know</i> how to determine the direction of a magnetic field produced by a current flowing in a straight wire or in a coil.
PH5. h.	<i>Students know</i> changing magnetic fields produce electric fields, thereby inducing currents in nearby conductors.
PH5. i.	<i>Students know</i> plasmas, the fourth state of matter, contain ions or free electrons or both and conduct electricity.

1

Angle between the spring gun and the horizon (degrees)	Range (meters)
20	6.4
30	8.6
40	9.8
50	9.6
60	8.7
70	6.3
80	3.4

The table shows the results of an experiment with a projectile fired from a spring gun. The results could be *most* easily interpreted if the data were

- A entered into a spreadsheet.
- B put into a database.
- C plotted in a histogram.
- D plotted as range vs. angle.

CSP00189

2

To create real-time graphs of an object's displacement versus time and velocity versus time, a student would need to use a

- A motion sensor.
- B low-g accelerometer.
- C potential difference probe.
- D force probe.

CSP10028

3

A student does an experiment to measure the acceleration of a falling object, which is $9.8 \frac{\text{m}}{\text{s}^2}$. The student obtains an experimental value of $14.6 \frac{\text{m}}{\text{s}^2}$. The reason for this variation is *most* likely due to

- A human error.
- B air resistance.
- C local fluctuations in gravity.
- D the mass of the object.

CSP00153

4

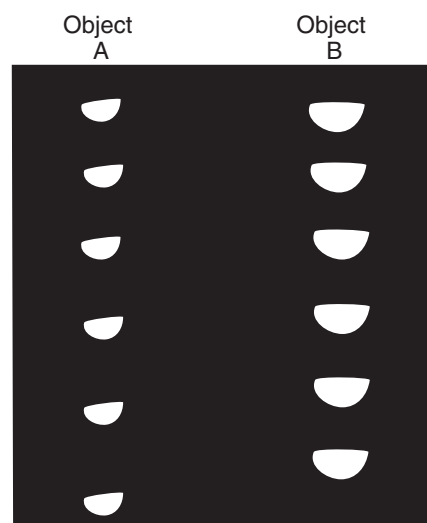

The picture shows two objects that were dropped and recorded with a stroboscopic camera. The *best* explanation for the results is that object A

- A has less air resistance.
- B was dropped from a greater height.
- C has a greater mass.
- D accelerated more slowly.

CSP00168

- 5 A student applied a constant force to a toy truck. A graph of the truck's movement is shown below.

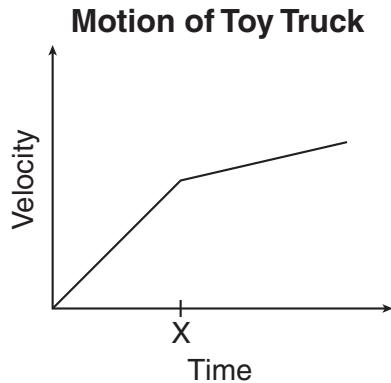

Which of the following could *best* explain the change in velocity at time X?

- A The truck's momentum became greater than its inertia.
- B The truck went from moving in a straight path to moving in a curved path.
- C The truck began traveling up a slightly sloped surface.
- D The truck went from rolling on a rough surface to rolling on a polished surface.

CSP20055

- 6 A student wires a series circuit that includes a block of rubber and a light bulb. She states that she does not expect the light bulb to light up when current is applied to the circuit. Which of the following *best* describes her statement?

- A It is a conclusion based on observed data about electrical phenomena.
- B It is a hypothesis based on knowledge of the theory of electrical phenomena.
- C It is a procedure based on her hypothesis about electrical phenomena.
- D It is a theory based on her observations of electrical phenomena.

CSP10489

- 7 A student attempts to measure the mass of a brick by measuring the force required to accelerate it at $1 \frac{\text{m}}{\text{s}^2}$ on a level surface. The force required is 2 N, and the student concludes that the brick has a mass of 2 kg. A balance shows that the mass of the brick is really 1.5 kg. The experimental error is *most* likely due to

- A gravity.
- B work.
- C friction.
- D inertia.

CSP10496

Released Test Questions

Physics

- 8 The graph below was presented to a science class.

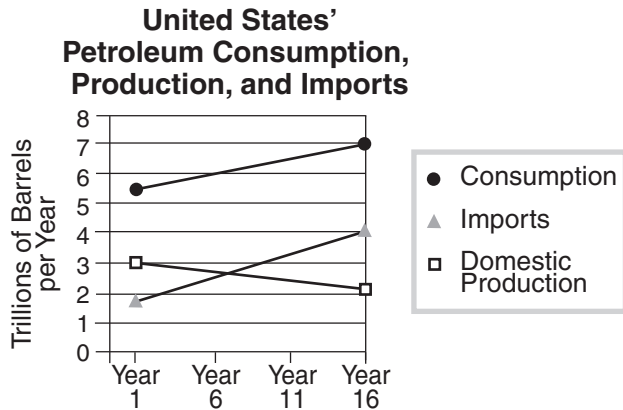

An accurate analysis of the data in the graph could be used to support a hypothesis that the United States has

- A become increasingly dependent on imported petroleum.
- B become more efficient in the conservation of petroleum.
- C regulated production by prohibiting companies from producing petroleum.
- D increased its reserves while consuming imported petroleum.

CSP20218

- 9 How much time will it take for a person to walk the length of a football field (100 yards) at a constant speed of $5 \frac{\text{ft}}{\text{s}}$?

- A 20 seconds
- B 33 seconds
- C 60 seconds
- D 166 seconds

CSP00260

- 10 A ball is dropped from rest from a height 6.0 meters above the ground. The ball falls freely and reaches the ground 1.1 seconds later. What is the average speed of the ball?

- A $5.5 \frac{\text{m}}{\text{s}}$
- B $6.1 \frac{\text{m}}{\text{s}}$
- C $6.6 \frac{\text{m}}{\text{s}}$
- D $11 \frac{\text{m}}{\text{s}}$

CSP10229

- 11 An object moves away from a motion detector with a constant speed. Which graph *best* represents the motion of the object?

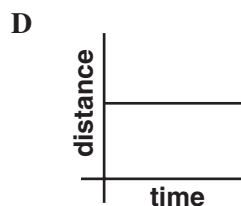
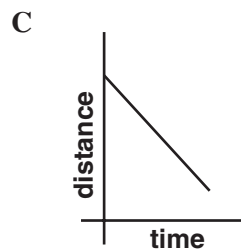
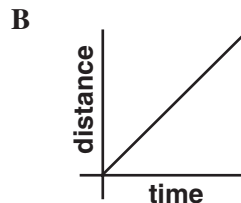

12 A 10-newton force and a 15-newton force are acting from a single point in opposite directions. What additional force must be added to produce equilibrium?

- A 5 N acting in the same direction as the 10-N force
- B 5 N acting in the same direction as the 15-N force
- C 10 N acting in the same direction as the 10-N force
- D 25 N acting in the same direction as the 15-N force

CSP00027

13 A student holds a book at rest in an outstretched hand. The force exerted on the book by the student is equal to the book's

- A mass.
- B weight.
- C volume.
- D density.

CSP00141

14 The graph below shows the velocity of a car that is moving in a straight line.

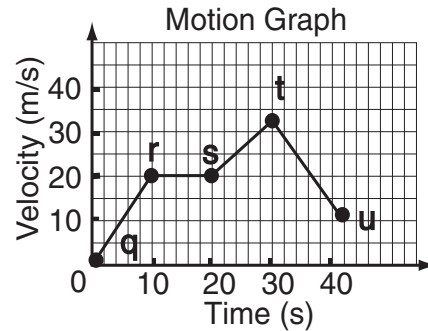

During which of the following intervals are forces on the car balanced?

- A q to r
- B r to s
- C s to t
- D t to u

CSP10121

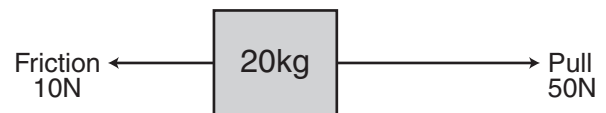
15

The figure shows a block that is being pulled along the floor. According to the figure, what is the acceleration of the block?

- A $2 \frac{\text{m}}{\text{s}^2}$
- B $3 \frac{\text{m}}{\text{s}^2}$
- C $4 \frac{\text{m}}{\text{s}^2}$
- D $6 \frac{\text{m}}{\text{s}^2}$

CSP00137

Released Test Questions

Physics

- 16 A 50-kg child on a skateboard experiences a 75-N force as shown.

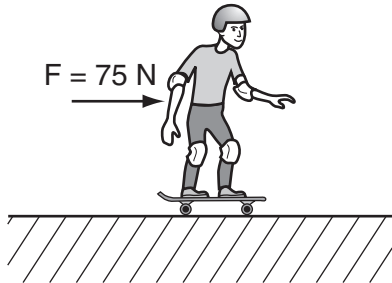

What is the expected acceleration of the child?

- A $0.67 \frac{\text{m}}{\text{s}^2}$
- B $1.50 \frac{\text{m}}{\text{s}^2}$
- C $6.70 \frac{\text{m}}{\text{s}^2}$
- D $25.00 \frac{\text{m}}{\text{s}^2}$

CSP10450

- 17 A soccer player kicks a 0.5-kilogram stationary ball with a force of 50 newtons. What is the force on the player's foot?

- A 0 N
- B 25 N
- C 50 N
- D 100 N

CSP00188

- 18 A student in a lab experiment jumps upward off a common bathroom scale as the lab partner records the scale reading.

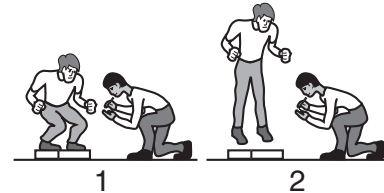

What does the lab partner observe during the instant the student pushes off?

- A The scale reading will remain unchanged during the entire time the student is in contact with the scale.
- B The scale reading will increase momentarily then will decrease as the student is moving upward from the scale.
- C The scale reading will increase during the entire time the student is in contact with the scale.
- D The scale reading will decrease momentarily then will increase as the student is moving upward from the scale.

CSP10451

- 19

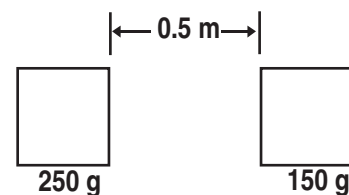

What event will produce the *greatest* increase in the gravitational force between the two masses?

- A doubling the large mass
- B doubling the distance between the masses
- C reducing the small mass by half
- D reducing the distance between the masses by half

CSP10467

- 20** Objects on the surface of Earth experience a large downward force although the universal gravitational constant is very small. Which of the following best explains this phenomenon?
- A Objects on Earth's surface exert a gravitational pull as strong as Earth's, regardless of the gravitational constant.
 - B The universal gravitational constant only describes relationships between small objects in outer space.
 - C Earth's mass is large enough that its gravity remains strong even when multiplied by a small constant.
 - D The universal gravitational constant increases in proportion with the mass of an object.

CSP20024

- 21** A communication satellite is in a circular orbit around Earth. If the speed of the satellite is constant, the force acting on the satellite
- A is zero.
 - B is decreasing.
 - C points toward the center of Earth at all times.
 - D points in the direction that the satellite is moving.

CSP00152

- 22** A satellite that is moving in a circular orbit around Earth and maintaining a constant speed will experience a
- A changing gravitational force toward Earth.
 - B net gravitational force toward Earth.
 - C changing acceleration away from Earth.
 - D net acceleration away from Earth.

CSP20728

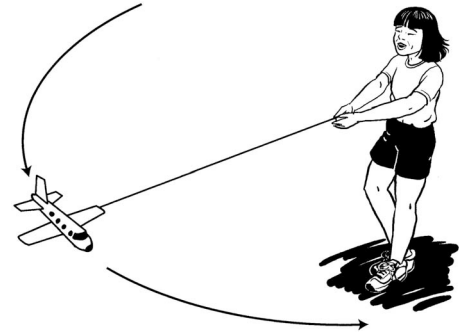
23

The picture shows the circular path of a toy plane being swung around on a string. What path would the toy take if the string broke?

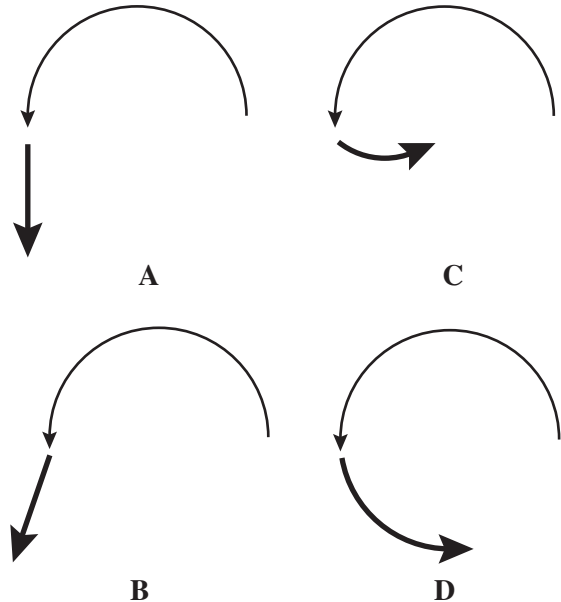

CSP00145

Released Test Questions

Physics

- 24 A ball on a rope swings around a vertical pole.

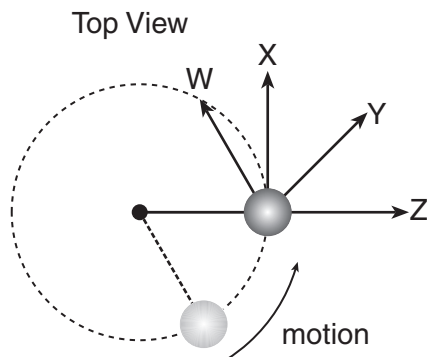

In which direction will the ball fly if released at the location shown?

- A W
 B X
 C Y
 D Z
- 25 A small car is being driven in a circular path at constant speed on a horizontal surface. What is the direction of the frictional force that keeps the car from skidding as it travels along this path?
- A opposite the direction of the velocity of the car
 B in the same direction as the velocity of the car
 C toward the center of the circle
 D outward from the center of the circle

CSP20185

CSP20292

- 26 A 2.0-kilogram mass is moving with a speed of $3.0 \frac{\text{m}}{\text{s}}$. What is the kinetic energy of the mass?
- A 1.5 J
 B 6.0 J
 C 9.0 J
 D 12.0 J

CSP00138

- 27 Three objects move with a velocity of $1 \frac{\text{m}}{\text{s}}$.

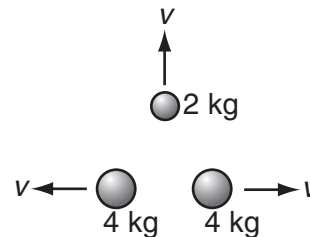

What is the total kinetic energy of the system?

- A 1 J
 B 2 J
 C 5 J
 D 10 J
- 28 What is the kinetic energy of an object with a mass of 10 kilograms traveling at a speed of 10 meters per second? Assume no other forces act upon the object.

CSP10435

- A 100 joules
 B 500 joules
 C 1000 joules
 D 50,000 joules

CSP00173

Physics

Released Test Questions

29 What is the kinetic energy of a 2-kg toy car moving at a velocity of $5 \frac{\text{m}}{\text{s}}$?

- A 5 J
- B 10 J
- C 25 J
- D 50 J

CSP20050

30 A 50-kilogram firefighter is on a ladder 10 meters above the ground. When the firefighter descends to 5 meters above the ground, the firefighter's gravitational potential energy will decrease by

- A 0.194 joules.
- B 5.10 joules.
- C 490 joules.
- D 2450 joules.

CSP00183

31 A hydraulic lift used at an automotive repair shop raises a 1000-kilogram car two meters off of the ground. What is the potential energy given to the car?

- A 1000 J
- B 2000 J
- C 9800 J
- D 19,600 J

CSP00171

32 A 5-kilogram mass is lifted from the ground to a height of 10 meters. The gravitational potential energy of the mass is increased by approximately

- A 0.5 J.
- B 50 J.
- C 250 J.
- D 500 J.

CSP10083

33 A high diver steps off a diving platform that is 10 meters above the water. If no air resistance is present, during the fall there will be a decrease in the diver's

- A gravitational potential energy.
- B total mechanical energy.
- C kinetic energy.
- D momentum.

CSP00164

34 A 2.5-kg brick falls to the ground from a 3-m-high roof. What is the approximate kinetic energy of the brick just before it touches the ground?

- A 75 J
- B 38 J
- C 12 J
- D 11 J

CSP10104

35 Starting from rest, a 2-kilogram block of wood slides a distance of two meters down a frictionless slope, as shown.

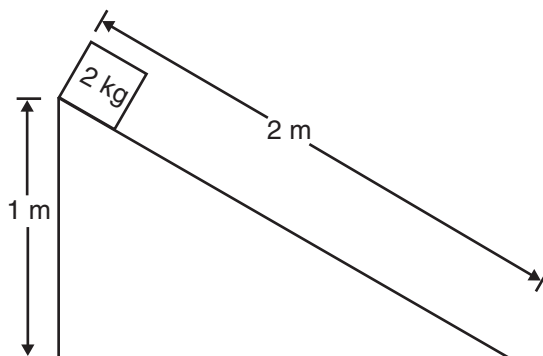

What is the approximate kinetic energy of the wooden block at the bottom of the slope?

- A 20 J
- B 40 J
- C 200 J
- D 400 J

CSP10156

36 A child is on a sled moving down a hill at $20 \frac{\text{meters}}{\text{second}}$. The combined mass of the sled and child is 100 kilograms. The momentum of the child and sled is

- A 5 kilogram $\cdot \frac{\text{m}}{\text{s}}$.
- B 20 kilogram $\cdot \frac{\text{m}}{\text{s}}$.
- C 1000 kilogram $\cdot \frac{\text{m}}{\text{s}}$.
- D 2000 kilogram $\cdot \frac{\text{m}}{\text{s}}$.

CSP00043

37 A 70-kg skier leaves a ski jump at a velocity of $14 \frac{\text{m}}{\text{s}}$. What is the skier's momentum at that instant?

- A 5 N•s
- B 50 N•s
- C 980 N•s
- D 9800 N•s

CSP20328

38 What is the momentum of an asteroid that has a mass of $1.35 \times 10^{12} \text{ kg}$ and a velocity of $2.55 \times 10^4 \frac{\text{m}}{\text{s}}$?

- A $1.89 \times 10^{-8} \frac{\text{kg m}}{\text{s}}$
- B $5.29 \times 10^7 \frac{\text{kg m}}{\text{s}}$
- C $3.44 \times 10^{16} \frac{\text{kg m}}{\text{s}}$
- D $8.78 \times 10^{20} \frac{\text{kg m}}{\text{s}}$

CSP20323

39 When is linear momentum conserved?

- A when only nonlinear forces are present
- B when more linear than nonlinear forces are in the system
- C when internal forces exceed external forces
- D when the net force on the system is zero

CSP00219

40 In collisions between two objects, kinetic energy is conserved only

- A if one of the objects was initially at rest.
- B if potential energy converts to work energy.
- C in inelastic collisions.
- D in elastic collisions.

CSP10085

- 41 A temporary force acting on a 2-kg object traveling at a velocity of $5 \frac{\text{m}}{\text{s}}$ causes the object to slow to a velocity of $2 \frac{\text{m}}{\text{s}}$. What was the decrease in momentum of the object?

- A $4 \text{ kg } \frac{\text{m}}{\text{s}}$
 B $5 \text{ kg } \frac{\text{m}}{\text{s}}$
 C $6 \text{ kg } \frac{\text{m}}{\text{s}}$
 D $7 \text{ kg } \frac{\text{m}}{\text{s}}$

CSP50175

42

10 Tons 30 Tons

4 m/s 0 m/s

Before

? m/s

After

When these two freight cars of different mass collide and couple, what will be their resultant velocity?

- A $1 \frac{\text{m}}{\text{s}}$
 B $2 \frac{\text{m}}{\text{s}}$
 C $4 \frac{\text{m}}{\text{s}}$
 D $8 \frac{\text{m}}{\text{s}}$

CSP00170

43 The diagram depicts a 2-kg mass colliding with and sticking to a second box.



What is the mass of the second box?

- A 4 kg
- B 6 kg
- C 8 kg
- D 9 kg

CSP10217

44 In an elastic collision, momentum is conserved, as is

- A kinetic energy.
- B potential energy.
- C speed.
- D velocity.

CSP20885

45 A cup of water at 40°C and a cup of water at 5°C are left on a table. Which graph correctly shows the temperature of the two cups of water as time passes?

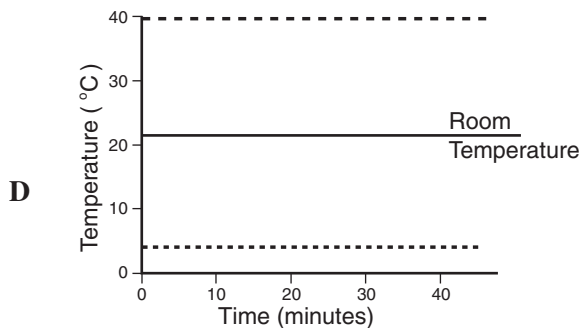
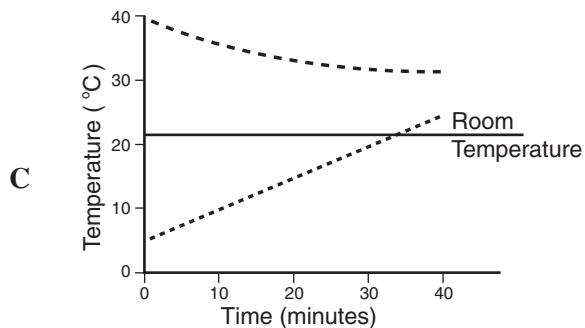
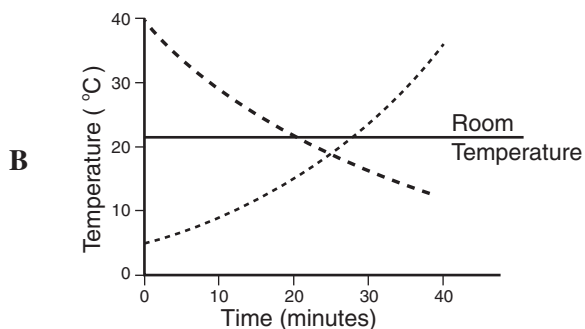
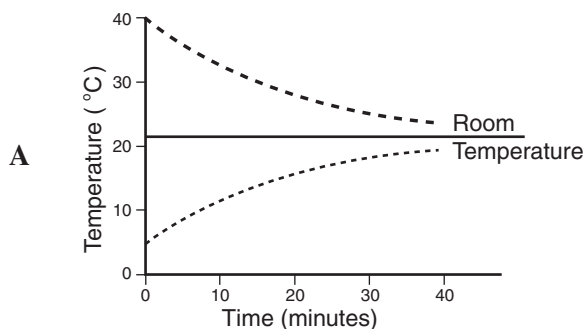

CSP00016

46 A heated gas expands, raising a piston. Which of the following describes the energy exchanges of this process?

- A Energy is transferred to the gas by the piston, and to the piston from the heat source.
- B Energy is transferred to the gas from the heat source, and to the raised piston from the gas.
- C Energy is transferred to the gas in the form of heat and work done by the piston.
- D Energy is transferred directly to the piston from the heat source.

CSP20508

47 When a steel block at 100°C is placed on top of a copper block at 20°C , the thermal energy of the copper begins to increase. Which of the following is the source of this increase in energy?

- A the work done by the molecules within the copper
- B the work done by the interaction of the two metals
- C heat flowing by means of conduction
- D heat flowing by means of radiation

CSP20564

48 An engine has an input of heat energy of $10,750\text{ J}$ and does 2420 J of work. Which of the following is the heat loss?

- A 0.225 J
- B 4.44 J
- C 8330 J
- D $13,170\text{ J}$

CSP00304

49 A proposed ideal heat engine would run with a high temperature reservoir at 800 kelvin and a low temperature reservoir at 300 kelvin . When the engine is running, it extracts 400 joules of energy from the hot reservoir and does 250 joules of work each minute. How much energy is expelled to the low temperature reservoir each minute?

- A 150 J
- B 250 J
- C 300 J
- D 400 J

CSP00199

50 The pressure of a gas inside a closed, rigid container will increase when the gas temperature increases. The pressure of the gas increases because the

- A density of the gas decreases.
- B rate of collisions of gas molecules with the surface increases.
- C container expands in size when heated.
- D gas molecules bond together to form more massive molecules.

CSP00149

- 51 A gas in a sealed cylinder is heated.

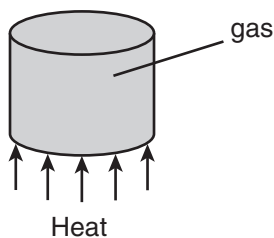

Which of the following does *not* increase as the gas is heated?

- A the average number of gas molecules hitting the cylinder walls per second
- B the average kinetic energy of the gas molecules
- C the average speed of the gas molecules
- D the average distance between the gas molecules

CSP00198

- 52 When a gas is heated in a closed container, the internal pressure increases. Which *best* describes the reason for the increase in pressure?

- A The average kinetic energy of the gas molecules decreases.
- B The potential energy of the gas increases.
- C The average kinetic energy of the gas molecules increases.
- D The potential energy of the gas decreases.

CSP00315

- 53 Molecules move about in random motion within a liquid. The total internal energy of the liquid depends on all of the following *except* its

- A temperature.
- B mass.
- C specific heat.
- D melting point.

CSP10306

- 54 In which of the following processes is the order of the system increasing?

- A shaking a jar containing separate layers of salt and pepper
- B smashing a coffee cup with a hammer
- C adding cold milk to a cup of hot coffee
- D forming crystals in a solution

CSP10109

- 55 A container of cold water is dumped into a larger container of hot water. It is mixed and then left alone for a long time interval. The water temperature is found to

- A randomly vary from region to region in the container.
- B be uniform throughout the container.
- C fluctuate at all positions in the container.
- D be greater at the bottom of the container.

CSP00116

- 56 Which of the following describes a system in which entropy is being increased?

- A Liquid water freezes to solid ice.
- B Air is compressed into a container.
- C Steam is condensed to a liquid.
- D Fuel is vaporized before burning.

CSP20537

Physics

Released Test Questions

- 57** Nitrogen molecules within a glass tube are allowed to move randomly. Which figure shows the molecules in a state of greatest entropy?

A

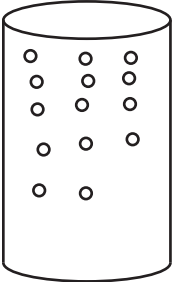

B

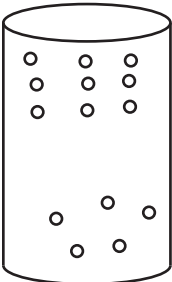

C

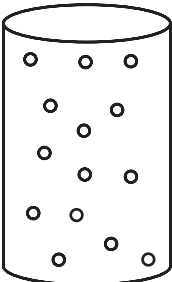

D

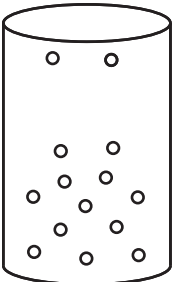

- 58** Entropy decreases when

- A wood burns.
- B water freezes.
- C a snowball melts.
- D an iron nail rusts.

CSP10070

- 59** A sound wave is produced in a metal cylinder by striking one end. Which of the following occurs as the wave travels along the cylinder?

- A Its amplitude increases.
- B Its frequency increases.
- C It transfers matter.
- D It transfers energy.

CSP10246

- 60** The graph below depicts the relationship between wave energy and wave amplitude.

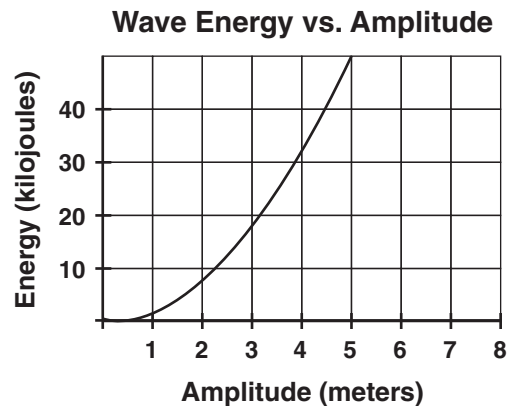

How is the energy of the wave affected if the amplitude of the wave increases from 2 meters to 4 meters?

- A It is halved.
- B It is doubled.
- C It is quadrupled.
- D It remains the same.

CSP20769

- 61** A radio station transmits to a receiving antenna. The radio wave sent is a

- A sound wave.
- B torsional wave.
- C longitudinal wave.
- D transverse wave.

CSP00303

CSP20089

Released Test Questions

Physics

- 62** A stretched spring attached to two fixed points is compressed on one end and released, as shown below.

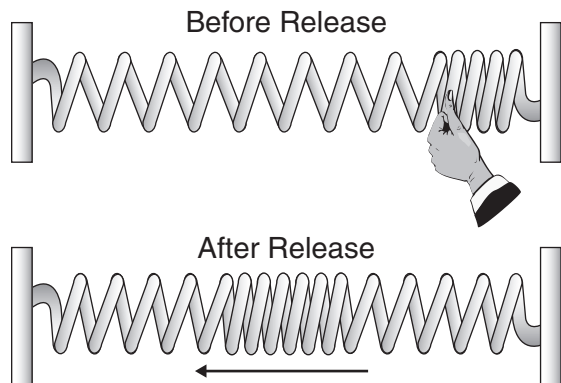

The resulting wave travels back and forth between the two fixed ends of the spring until it comes to a stop. This mechanical wave is an example of a

- A transverse wave.
 B longitudinal wave.
 C superpositioned wave.
 D refracted wave.
- 63** One end of a horizontal string is caused to oscillate vertically while the other end is attached to a fixed object. The wave that travels along the string is an example of

- A an electromagnetic wave.
 B a transverse wave.
 C a microwave.
 D a longitudinal wave.

- 64** A sound wave traveling through a solid material has a frequency of 500 hertz. The wavelength of the sound wave is 2 meters. What is the speed of sound in the material?

- A $250 \frac{\text{m}}{\text{s}}$
 B $500 \frac{\text{m}}{\text{s}}$
 C $1000 \frac{\text{m}}{\text{s}}$
 D $250,000 \frac{\text{m}}{\text{s}}$

CSP00159

- 65** A tuning fork is used to produce sound waves with a frequency of 440 hertz. The waves travel through the air at $344 \frac{\text{m}}{\text{s}}$. What is the wavelength of the sound waves?

- A 0.15 m
 B 0.39 m
 C 0.78 m
 D 1.28 m

CSP00227

- 66** A student shakes the end of a rope with a frequency of 1.5 Hz, causing waves with a wavelength of 0.8 m to travel along the rope. What is the velocity of the waves?

- A $1.9 \frac{\text{m}}{\text{s}}$
 B $1.6 \frac{\text{m}}{\text{s}}$
 C $1.2 \frac{\text{m}}{\text{s}}$
 D $0.53 \frac{\text{m}}{\text{s}}$

CSP10461

67 What is the wavelength of a 264-Hz sound wave when the speed of sound is $345 \frac{\text{m}}{\text{s}}$?

- A 0.77 m
- B 1.31 m
- C 6.09 m
- D 9.11 m

CSP10247

68 Astronauts on the Moon would *not* be able to hear a landslide because

- A the lunar dust deadens sounds.
- B intensive sunlight destroys sound waves.
- C the magnetic field of the Moon is too weak to carry sound.
- D air molecules on the Moon are too far apart to carry sound.

CSP00069

69 Sound waves cannot carry energy through

- A water.
- B air.
- C a mirror.
- D a vacuum.

CSP20090

70 Where does visible light fall on the electromagnetic spectrum?

- A between x-rays and gamma rays
- B between short-wave radio and television
- C between infrared and ultraviolet
- D between microwaves and infrared

CSP00181

71 In a vacuum, radio waves, visible light, and x-rays all have the same

- A wavelength.
- B speed.
- C frequency.
- D energy.

CSP20201

72 Objects appear different in size and shape in a container of water due to

- A refraction of the light waves.
- B interference of the water and light waves.
- C polarization of the light waves.
- D diffraction of the light waves.

CSP00158

73 An engineer in a moving train blows the train's horn. The train is moving away from a person standing on the ground. Compared to the frequency of the sound that the engineer hears, the person standing on the ground hears a sound with

- A the same wavelength.
- B more variation in tone.
- C greater amplitude.
- D a lower frequency.

CSP00146

Released Test Questions

Physics

74

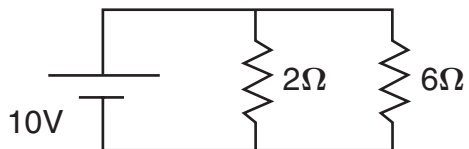

In this circuit, what is the current through the 2-ohm resistor?

- A 0.2 A
- B 0.8 A
- C 5.0 A
- D 8.0 A

CSP00155

75

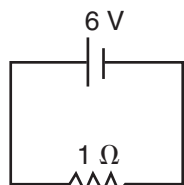

total resistance = $1\ \Omega$
current = 6 A

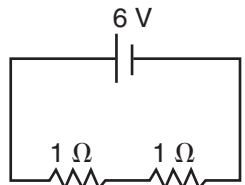

total resistance = $2\ \Omega$
current = 3 A

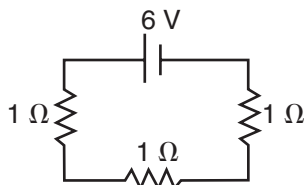

total resistance = $3\ \Omega$
current = 2 A

How many amperes of current will flow when four 1-ohm resistors are in this series circuit?

- A 0.5 ampere
- B 1.0 ampere
- C 1.5 amperes
- D 2.0 amperes

CSP00182

76

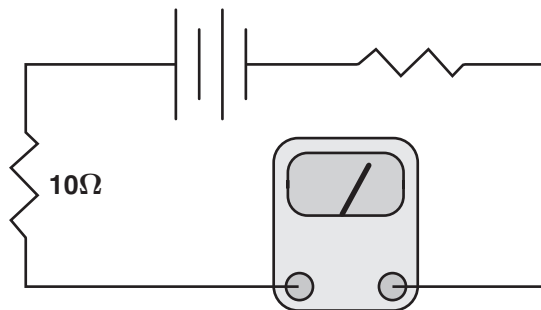

In the circuit shown above, the meter registers 1.5 amperes. The voltage across the 10.0-ohm resistor is about

- A 1.5 V.
- B 6.7 V.
- C 8.5 V.
- D 15.0 V.

CSP00185

77

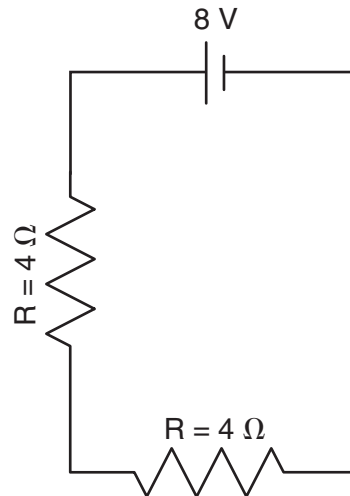

What is the current through the battery?

- A 1 A
- B 2 A
- C 4 A
- D 8 A

CSP00117

Physics

Released Test Questions

78 A 9-V battery is connected to a light bulb with a resistance of $3\ \Omega$. What is the current in the circuit?

- A 27 A
- B 3.0 A
- C 1.0 A
- D 0.3 A

CSP20116

79 An electric appliance draws 1.5 amperes of current when it is connected to a 24-volt source. What is the resistance of this appliance?

- A 0.063 ohm
- B 11 ohms
- C 16 ohms
- D 54 ohms

CSP10178

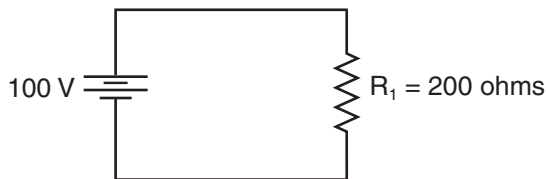
80

How much power is dissipated by the resistor in the circuit above?

- A 25 watts
- B 50 watts
- C 100 watts
- D 800 watts

CSP20505

81 Superconductors are materials that appear to exhibit no resistance. Therefore, electrons passing through a superconductor will

- A generate no current.
- B generate no heat.
- C increase the current's power.
- D decrease the electrons' charges.

CSP20046

82 A transistor circuit is used as an amplifier. When a signal is applied to the input of the transistor, the output signal is

- A a smaller amplitude.
- B an equal amplitude.
- C a larger amplitude.
- D zero amplitude.

CSP00057

83 Two oppositely charged particles are held in place near each other. When the particles are released, they will *most* likely

- A accelerate away from each other.
- B accelerate toward each other.
- C rotate in a clockwise direction.
- D rotate in a counterclockwise direction.

CSP20654

84 A metal bar magnet has a magnetic field in the region of space around it. The magnetic field is due to

- A magnetic monopoles embedded in the metal.
- B a hidden voltage source in the metal.
- C the motion of charged particles in the metal.
- D an electric current that runs along the length of the magnet.

CSP00008

85

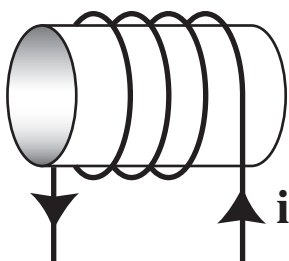

A coil with a current is shown above. In the center of the coil, a magnetic field points

- A to the right.
- B to the left.
- C upward.
- D downward.

CSP00135

86 The diagram below shows current flow through a wire.



Which of the following represents the magnetic field resulting from the current?

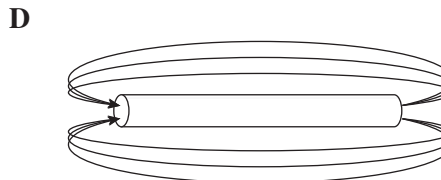
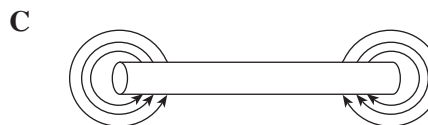
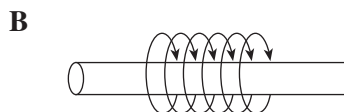
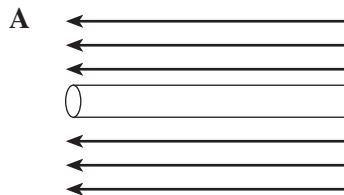

CSP20176

- 87** Students in a lab measure a current flowing through a long loop of wire.

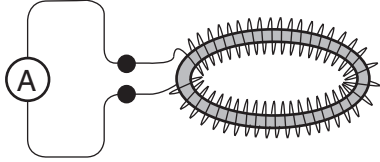

If there is no current source connected to the wire, which of the following explains the source of the current?

- A The ammeter is acting as a current source.
- B There is an oscillating magnetic field inside the loop.
- C There is a fixed current running in a separate wire along the axis of the loop.
- D There is a static configuration of positive charge external to the loop.

CSP10268

- 88** In order to turn neon gas into neon plasma,

- A energy must be removed from the neon gas.
- B energy must be supplied to the neon gas.
- C the neon gas must be ignited with a flame.
- D the neon gas must become a superconductor.

CSP00110

- 89** Extremely high temperatures are needed for fusion reactors to function efficiently. What state of matter is *most* common at these temperatures?

- A plasma
- B gas
- C liquid
- D solid

CSP10464

Question Number	Correct Answer	Standard	Year of Release
1	<i>D</i>	PHIE1.A	2006
2	<i>A</i>	PHIE1.A	2006
3	<i>A</i>	PHIE1.B	2003
4	<i>A</i>	PHIE1.C	2003
5	<i>C</i>	PHIE1.D	2007
6	<i>B</i>	PHIE1.F	2004
7	<i>C</i>	PHIE1.J	2005
8	<i>A</i>	PHIE1.M	2008
9	<i>C</i>	PH1.A	2003
10	<i>A</i>	PH1.A	2005
11	<i>B</i>	PH1.A	2007
12	<i>A</i>	PH1.B	2004
13	<i>B</i>	PH1.B	2006
14	<i>B</i>	PH1.B	2008
15	<i>A</i>	PH1.C	2003
16	<i>B</i>	PH1.C	2006
17	<i>C</i>	PH1.D	2003
18	<i>B</i>	PH1.D	2005
19	<i>D</i>	PH1.E	2006
20	<i>C</i>	PH1.E	2008
21	<i>C</i>	PH1.F	2004
22	<i>B</i>	PH1.F	2007
23	<i>A</i>	PH1.G	2004
24	<i>B</i>	PH1.G	2007
25	<i>C</i>	PH1.G	2008
26	<i>C</i>	PH2.A	2003
27	<i>C</i>	PH2.A	2005
28	<i>B</i>	PH2.A	2007
29	<i>C</i>	PH2.A	2008
30	<i>D</i>	PH2.B	2003
31	<i>D</i>	PH2.B	2005
32	<i>D</i>	PH2.B	2006
33	<i>A</i>	PH2.C	2004
34	<i>A</i>	PH2.C	2005
35	<i>A</i>	PH2.C	2008
36	<i>D</i>	PH2.D	2004
37	<i>C</i>	PH2.D	2006
38	<i>C</i>	PH2.D	2007

Question Number	Correct Answer	Standard	Year of Release
39	<i>D</i>	PH2.E	2004
40	<i>D</i>	PH2.E	2007
41	<i>C</i>	PH2.F	2008
42	<i>A</i>	PH2.G	2004
43	<i>A</i>	PH2.G	2005
44	<i>A</i>	PH2.G	2008
45	<i>A</i>	PH3.A	2004
46	<i>B</i>	PH3.A	2006
47	<i>C</i>	PH3.A	2008
48	<i>C</i>	PH3.B	2005
49	<i>A</i>	PH3.B	2006
50	<i>B</i>	PH3.C	2003
51	<i>D</i>	PH3.C	2003
52	<i>C</i>	PH3.C	2004
53	<i>D</i>	PH3.C	2008
54	<i>D</i>	PH3.D	2004
55	<i>B</i>	PH3.D	2005
56	<i>D</i>	PH3.D	2008
57	<i>C</i>	PH3.E	2007
58	<i>B</i>	PH3.E	2007
59	<i>D</i>	PH4.A	2006
60	<i>C</i>	PH4.A	2006
61	<i>D</i>	PH4.B	2003
62	<i>B</i>	PH4.B	2005
63	<i>B</i>	PH4.B	2008
64	<i>C</i>	PH4.C	2003
65	<i>C</i>	PH4.C	2005
66	<i>C</i>	PH4.C	2006
67	<i>B</i>	PH4.C	2007
68	<i>D</i>	PH4.D	2004
69	<i>D</i>	PH4.D	2007
70	<i>C</i>	PH4.E	2007
71	<i>B</i>	PH4.E	2008
72	<i>A</i>	PH4.F	2003
73	<i>D</i>	PH4.F	2004
74	<i>C</i>	PH5.A	2003
75	<i>C</i>	PH5.A	2005
76	<i>D</i>	PH5.B	2003

Question Number	Correct Answer	Standard	Year of Release
77	<i>A</i>	PH5.B	2005
78	<i>B</i>	PH5.B	2006
79	<i>C</i>	PH5.B	2007
80	<i>B</i>	PH5.C	2007
81	<i>B</i>	PH5.C	2008
82	<i>C</i>	PH5.D	2005
83	<i>B</i>	PH5.E	2007
84	<i>C</i>	PH5.F	2004
85	<i>B</i>	PH5.G	2005
86	<i>B</i>	PH5.G	2006
87	<i>B</i>	PH5.H	2008
88	<i>B</i>	PH5.I	2004
89	<i>A</i>	PH5.I	2006

Formulas

Average Speed: $v = \frac{\Delta x}{\Delta t}$

Uniformly Accelerated Motion: $v = v_o + at$

$$x = x_o + v_o t + \frac{1}{2} at^2$$

Newton's Second Law: $F = ma$

Centripetal Force: $F = \frac{mv^2}{r}$

Law of Universal Gravitation: $F = \frac{Gm_1m_2}{r^2}$

Force Due to Gravity: $F = w = mg$

Work: $W = Fd$

Kinetic Energy: $E = \frac{1}{2}mv^2$

Gravitational Potential Energy: $E = mgh$

Momentum: $p = mv$

Collision in One Dimension: $[m_1v_1 + m_2v_2]_{initial} = [m_1v_1 + m_2v_2]_{final}$

Heat Energy: $Q = mc\Delta T$

First Law of Thermodynamics: $\Delta U = Q + W_{(on\ the\ system)}$

$$\Delta U = Q - W_{(by\ the\ system)}$$

Work by a Heat Engine: $W = Q_H - Q_L$

Change in Entropy: $\Delta S = \frac{Q}{T}$

Wave Speed: $v = f\lambda$

Current: $I = \frac{q}{t}$

Ohm's Law: $V = IR$

Power Dissipated in a DC Circuit: $P = IV$

Power Dissipated in a Resistor: $P = I^2R$

Units

Force: $1\text{ N} = 1 \frac{\text{kg m}}{\text{s}^2}$

Energy: $1\text{ J} = 1\text{ N m}$

Power: $1\text{ W} = 1 \frac{\text{J}}{\text{s}}$

Constants

Gravitational Constant: $G = 6.67 \times 10^{-11} \frac{\text{N m}^2}{\text{kg}^2}$

Acceleration Due to Gravity: $g = 9.8 \frac{\text{m}}{\text{s}^2}$

Speed of Light in a Vacuum: $c = 3.00 \times 10^8 \frac{\text{m}}{\text{s}}$